

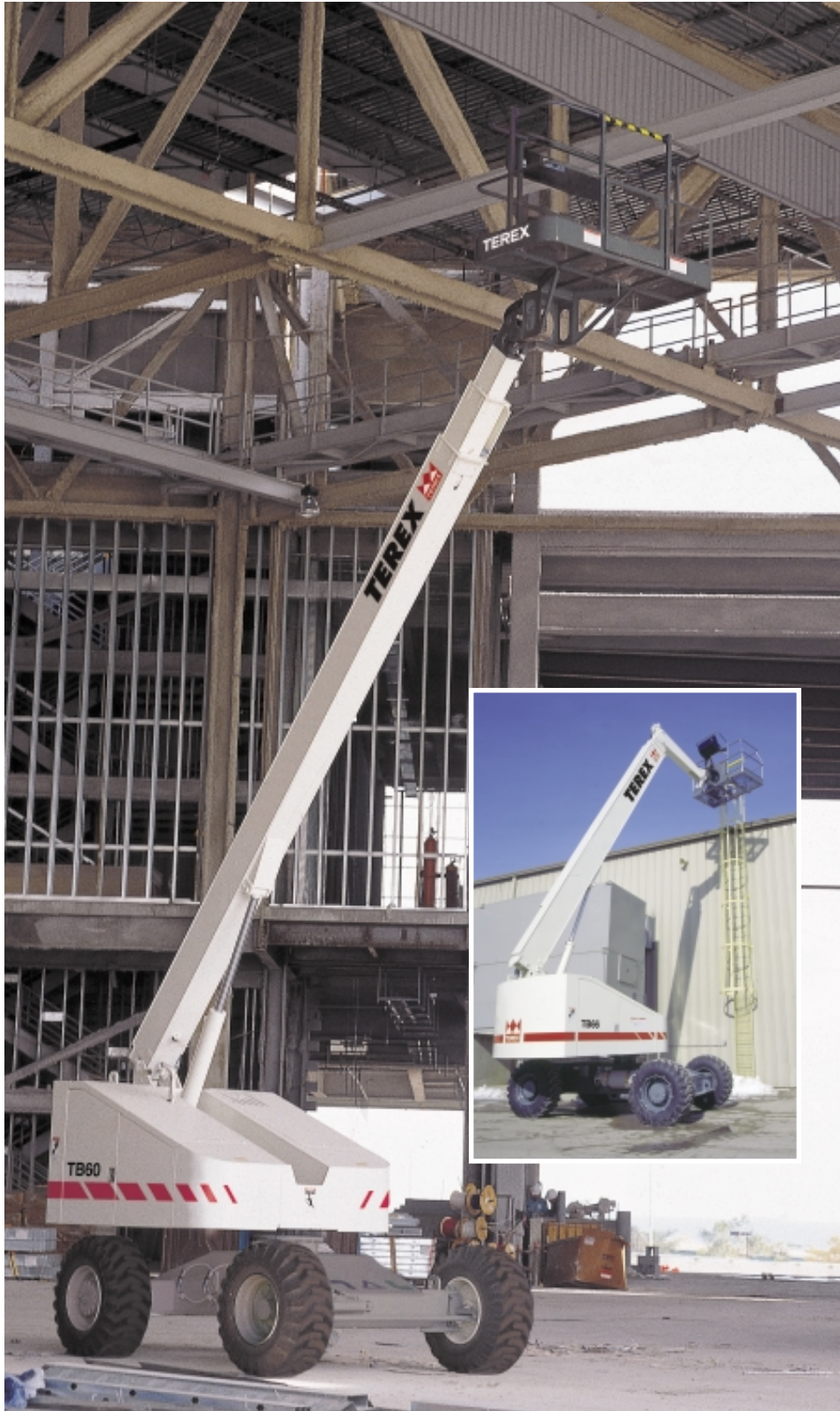

TEREX TB60/TB66

Telescopic Boom Lifts



FEATURES

- 60 ft. (18.29 m) and 66 ft. (20.12 m) maximum platform heights
- 650 lbs. (295 kg) and 500 lbs. (227 kg) maximum platform capacities
- Unique drive system provides excellent mobility
- 4-wheel drive, oscillating axle standard
- Microprocessor controller for exceptional reliability and serviceability
- Articulating jib on TB66
- Quick change platform arrangement simplifies platform removal or replacement
- Choice of water-cooled gasoline engine or diesel engines. All equipped with anti-restart
- 5-year structural warranty, 1-year parts and labor warranty
- Terex Support Plus product service

simple, available and
cost effective™

Machines shown may have optional equipment.

TEREX TB60 / TB66 SPECIFICATIONS

Description	TB60	TB66
Height - Working (maximum)	66' (20.12 m)	72' (21.95 m)
Platform (maximum)	60' (18.29 m)	66' (20.12 m)
Stowed	8' 6" (2.59 m)	9' 3" (2.82 m)
Length (overall)	26' 1-1/4" (7.96 m)	28' 11" (8.81 m)
Width (maximum)	7' 11" (2.41 m)	7' 11" (2.41 m)
Horizontal Reach	51' 4-5/8" (15.66 m)	57' 4-5/8" (17.49 m)
Boom Angle - Above Horizontal	75°	75° + 15° Articulating
Below Horizontal	-20°	-20° -80° Articulating
Std. Platform Dimensions	72" x 36" x 44" (1.83 m x 0.91 m x 1.12 m)	72" x 36" x 44" (1.83 m x 0.91 m x 1.12 m)
Load Capacity (maximum)	650 lbs. (295 kg)	500 lbs. (227 kg)
Opt. Platform Dimensions	96" x 36" x 44" (2.44 m x 0.91 m x 1.12 m)	N/A
Load Capacity (maximum)	600 lbs. (272 kg)	N/A
Platform Rotation	160°	160°
Wheelbase	8' 0" (2.44 m)	8' 0" (2.44 m)
Wheel Track	6' 7" (2.01 m)	6' 7" (2.01 m)
Turret Tailswing	42" (1.07 m)	42" (1.07 m)
Turret Rotation	360° Continuous	360° Continuous
Turning Radius - Outside Curb	16' 9" (5.1 m)	16' 9" (5.1 m)
Travel Speed	0 - 3.0 mph (0 - 4.83 km/h)	0 - 3.0 mph (0 - 4.83 km/h)
Gradeability*	30% (16 deg) - Std. 2WD 50% (27 deg) - Opt. 4WD	25% (14 deg) - Std. 2WD 50% (27 deg) - Opt. 4WD
Controls		
Boom Functions	Proportional	Proportional
Drive	Proportional	Proportional
Power Source	Water-cooled gasoline 66 hp (49.2 kw)	Water-cooled gasoline 66 hp (49.2 kw)
Fuel Tank Capacity	40 gal. (151 L)	40 gal. (151 L)
Hydraulic System	Load sensing pressure compensating	Load sensing pressure compensating
Reservoir Capacity	52 gal. (197 L)	52 gal. (197 L)
Tires (monofilled)	15 x 19.5 13 P.R. (loader lug)	15 x 19.5 13 P.R. (loader lug)
Ground Clearance	10" (0.25 m)	10" (0.25 m)
Approx. Shipping Weight	23,000 lbs. (10 443 kg)	25,000 lbs. (11 340 kg)

*Gradeability data is theoretical and is limited by tire slip, stability, or engine oil pan design.

STANDARD EQUIPMENT

- Choice of Cummins 4B3.9 - 76 hp (56.7 kw) water-cooled diesel engine, Deutz F4L1011 - 56 hp (41.7 kw) air-cooled diesel engine or Ford LRG425 66 hp (49.2 kw) water-cooled gasoline engine with dual fuel kit
- Four wheel drive
- Oscillating axle
- All-steel, high strength booms
- All function auxiliary power
- Spring applied, hydraulically released parking brakes
- Swing gate
- Positive ignition start switch
- Infinitely variable proportional controls
- Energy efficient hydraulic system w/load sensing and pressure compensating capabilities
- Engine anti-restart system
- Automatic platform leveling
- 110 or 220 VAC wiring and GFI receptacle to platform
- Multi-axial slope sensor with alarm
- Fluid level indicators
- Auxiliary controls at ground level
- Quick change all steel work platform
- Recessed platform top rail
- Lanyard eyelets for safety harness attachment
- Guarded foot and hand controls with return to neutral feature
- Emergency all-power shut down switch on console
- Fully accessible hydraulic/electric componentry
- Monofilled tires
- Lifting lugs
- Hourmeter
- All motion alarm
- Flashing amber beacon
- Totally enclosed external power track
- Articulating jib (TB66 only)
- Terex Support Plus product service

OPTIONS

- 8' (2.44 m) Universal platform (In place of standard 6' (1.83 m) – TB60 only)
- Glass handling platform (In place of standard 6' (1.83 m) – TB60 only)
- Compressed air line to platform – 1/2" (1.27 cm) with hose reel
- Hydraulic line to platform with hose reel
- 4-wheel steer (not available on fixed axle unit)
- Towing package (Includes tow bar) – Fixed axle machines only
- Hostile environment package
- 120V AC generator
- 220V AC generator
- Head or tail lights
- Directional correcting controls
- Platform work light - Halogen
- Spark arrestor muffler (Standard on Cummins engine)
- Engine block heater (Cummins engine)
- Lube oil heater (Cummins engine)
- Push button warning horn
- EC Compliance Package

For more information, product demonstration, or details on lease and rental plans, please contact your local Terex Aerials Distributor.

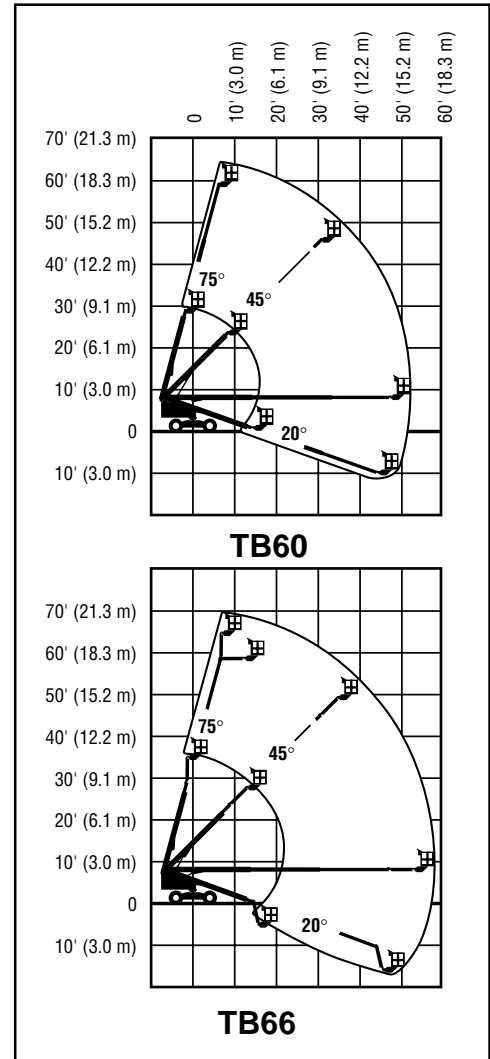

We reserve the right to amend these specifications at any time without notice. The only warranty applicable is our standard written warranty applicable to the particular product and sale. We make no other warranty, expressed or implied.

TEREX AERIALS

106 12th Street S.E.
Waverly, IA 50677-9466 USA
(319) 352-3920 • FAX: (319) 352-5727
E-mail: waverly@terexlifting.com

www.terexlift.com